



Newsletter of THE PALMERSTON NORTH MODEL ENGINEERING CLUB INC
Managers of the "MARRINER RESERVE RAILWAY"
Please address all correspondence to :- 22b Haydon St, Palmerston North.

PRESIDENT
Chris Rogers
(06) 356-1759

SECRETARY
Murray Bold
(06) 355-7000

TRACK CONVENOR
Richard Lockett
(06) 323-0948

EDITOR
Doug Chambers
(06) 354-9379

**October 2005
No 306**

PNMEC Home Page www.pnmeec.org.nz
Email:- pnmeec@clear.net.nz

TRACK RUNNING

This is held on the FIRST and THIRD Sunday of each month, from 1 pm to 4 pm Summer and 1 pm to 3 pm during the Winter. All club members are welcome to attend and help out with loco coaling, watering and passenger marshalling - none of the tasks being at all onerous.

Visiting club members too, are always welcome at the track, at the monthly meeting, or if just visiting and wishing to make contact with members, please phone one of the above office bearers.

Sender:- PNMEC
22b Haydon St,
Palmerston North

Place
stamp
here

November End of Year Function - See bottom of page 5 for details

This Months Featured Model



**T
H
E

G
E
N
E
R
A
T
O
R**

SEPTEMBER MEETING.

Club visit to 3 Squadron RNZAF 22 September

A bus load of members of PNMEC journeyed to Ohakea on the evening of 22 September to visit No 3 squadron who operate the fourteen Iroquois UH- 1H helicopters of the Royal New Zealand Air Force.

These helicopters are now a familiar sight and sound in the Manawatu since being based at Ohakea and came in handy during the big flood of February 2004, civil defense being one of their non military tasks along with support to the NZ police (search and rescue), Department of Conservation and the Internal Affairs (VIP transport).

The main role of the Iroquois is to provide Tactical Air Mobility for army troops with 5 fully equipped troops or 9 unequipped passengers able to be lifted.

All fourteen helicopters were in the hanger at the time of our visit and we were able to climb all over two of the machines and examine in detail one, which was dismantled for serious maintenance which included the Lycoming T53-L13B jet engine, gearbox, rotor assembly and were able to ask tricky questions of our hosts Sergeant Stephen Morgan and Sergeant Rewiri Tahī-Martin.

A very enjoyable evening was had with thanks to 3 Squadron Royal New Zealand Air Force and to ALPHA Buses whose driver didn't get lost getting us there.

OCTOBER MEETING

This will be held in the Hearing Association Rooms, Church Street, Palmerston North on the 27th October at 7.30pm. The theme for the evening is to be 'Bits and Pieces' so members are requested to bring along their current project.

Wanted to Buy

A Rodney Mill-drill of the type that will fit on a Myford ML7 or Super Seven lathe
Contact Bernie Coyne Phone 06 753 4528.

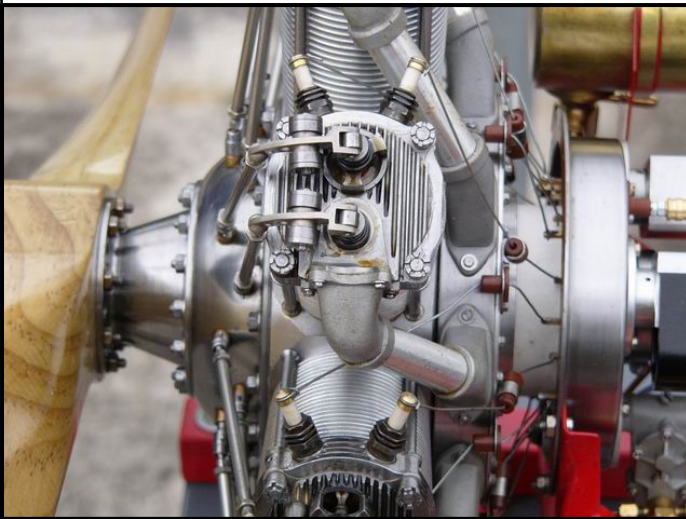

COMING EVENTS

Mid Week Run at Marriner Reserve Railway

25th October between 10.00 am and 2.00 pm
Please contact Doug Chambers beforehand.

Track running at Marriner Reserve Railway

6th November 1 – 4pm
20th November 1 – 4 pm

OPEN WEEKENDS

Havelock North	Labour Weekend
New Plymouth	Labour Weekend
Tauranga	12 th and 13 th November

BENTLEY ROTARY RUNS

On the 2nd October 2005 Graeme Hall brought his newly finished Bentley 9 cylinder rotary aircraft engine along to the running day. He ran it three or four times during the afternoon to the delight of the PNME members there. Fabulous sound and smell. The members were surprised at how easily it started and how smoothly it ran. Marvellous effort Graeme!!!!

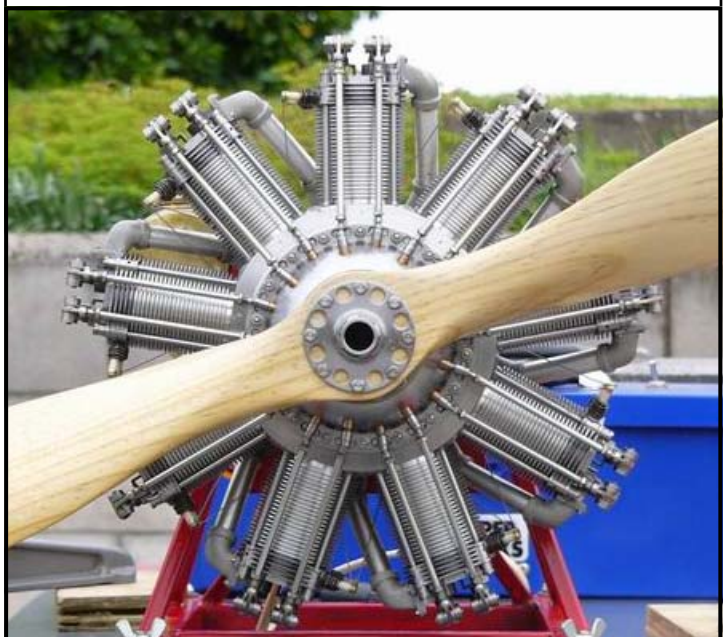

The closing date for the next issue of The Generator is Friday 11 November

LETTER from ENGLAND

By Stan Compton

Recently the Hereford Society was invited to put on a display at the 2005 Model Engineering Exhibition at Bristol. Richard Donovan organised everything, choice of exhibits etc. We were allocated seven metres of table space right opposite Tracey Tools. It was interesting to watch Tracey, she is a woman with I suspect a young family, selling their wares, there is not much she does not know about tooling.

For once the visitors to the Exhibition were mostly Model Engineers who took a real interest in our display items.

My 'La France' fire engine was attractive to the lady visitors, then I realised it positively glistened from the lighting provided in the venue, a leisure centre used for sporting activities. Then someone remarked that the lights were the same ones that are fitted in jewellery shop windows to make the goods sparkle. With such limited space Richard asked for a five-inch gauge Single Fairlie locomotive. This was mounted on a section of curved track to display the engine's flexibility. The next model was a beam engine 'Lady Stephanie'; this is a very pretty model and has been motorised creating a working effect.

The third exhibit was a pretty clock in its glass dome and the fourth was my 'La France' fire engine. The fifth exhibit was my 'Locomotion' in 1 1/2" scale. Years ago I added a drive belt, hidden from view and a removable crank handle to be able to rotate the motion. This feature was worth the effort.

The sixth item was a 5" gauge brake van and shunters truck.

The seventh item was a 3 1/2" gauge tank 'Mona' which had been acquired and overhauled by one of our members.

The last items were three spirit fired locomotives in Gauge 1 with a rolling road for each to be displayed in steam. These were beautifully finished, and one was an unusual Caledonian Railway 4-6-2 tank. So just a small display but worth the effort. I volunteered to spend a day on the stand and unlike when at a Traction Engine Rally visitors asked intelligent questions.

One man had me beat though. New to model engineering, he was building a small air-cooled petrol engine after having first made an oscillating steam engine.

"What did you use for a boiler to test run the steam engine?" I asked. He replied that he had used an empty gas cylinder with an adaptor for a rubber hose to take the steam to the cylinder knowing that the rubber hose would act as a safety valve. When placed on a gas burner he could raise steam, a bit like LBSC

as a child with his cocoa tin boiler!!!!

Now to find an answer to his problem of cutting the fins on his air-cooled engine. The metal was building up on his parting tool even though he was using kerosene. I recommended more top rake and for him to buy some neat cutting oil. I even took him over to Reeves stand nearby and indicated the 1/2 litre container of cutting oil available for just a few pounds. Reeves manager on the stall was listening to the man's comment that LBSC recommended "Bacon frying oil", we both smiled at this comment and I explained that LBSC meant you must hear the sound of bacon frying to know that the cut was taking place. Later I asked if the man had bought any cutting oil, "Oh no, I've met them before, you can't get their money out of their pockets"!!!!

When I thought I had got rid of all this visitors questions he came up with, "How can I keep the chips of metal out of the washing?" It seemed his wife was complaining because he had the lathe in the garage next to the washing machine. My answer was to move the lathe into the garden shed and make that a workshop.

When acting as a steward on the display stand there is not much time to look at other exhibits, but I was able to hear about problems some men had. For instance the builder of an aircraft radial engine found he had machined the exhaust ports at the wrong angle, this meant scrapping the lot and starting again!!!! That is dedication. A useful tip came from the builder of hot air engines, friction kills the power available so even a new ball race needs to have all the grease washed out before using it.

I spoke to a man who had a rolling ball in a test tube device ticking away with a meths burner providing the heat source. The test tube was held in a Terry spring clip, the sort you can use to mount tools on a board, this allowed a small adjustment to get the balance correct. He told me that even a piece of thin card put under one end of the base could help here. I built one of these devices and it took some time to make it work, a larger flywheel helped.

On our last trip round the South Island with Unique Tours from Palmerston North we spent a few days in Christchurch. One of the men on the coach tour suggested we visit a Vintage Car museum located out near the airport. I suggested taking a taxi. "Oh no. That will cost too much. We will take a bus from the city centre to the outskirts and then find a taxi." We located the modern bus station, very efficient, just like an airport. We got on the bus and showed the driver the brochure describing the museum and asked to be put off near the location. He did better than that, out in the suburbs he stopped the bus and told us to follow him up to the front door of a house. He

knocked and the driver of a taxi parked outside appeared.
 "These two men want to go to the Car Museum" said the bus driver.
 "But I am just having my dinner" said the taxi driver.
 "Leave your dinner, put your shoes on and take these men out and have your dinner when you get back."
 Our bus driver turned to us and said, "He will look after you." Then he got back in the bus, the engine still running and drove off. Where else would you get such service?

NEW ZEALAND RAILWAYS Class D

By Doug Chambers

These 2-4-0 tank engines owed much of their design to Carl Pihl who had drawn up a very similar locomotive for the 3'6" section of the Norwegian Railways in 1866. The inclined cylinders and running plate

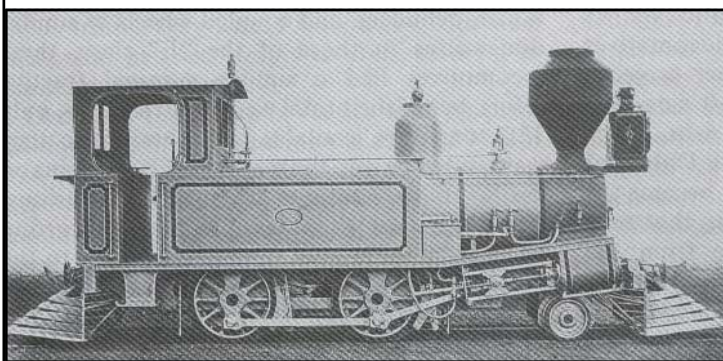

had their origins in the Beyer, Peacock and Company's renowned 'Metropolitan' type tank design. The first batch of seven were ordered from Neilson and Company in 1874, followed by a further four in 1878 and five more built by Dubs and Company the same year.

In 1880 a further six were ordered from Neilsons. In 1884 Scott Bros of Christchurch, New Zealand were awarded a contract for a further ten. Scott Bros built another for the Napier Harbour Board and another for the Midland Railway Company. This last one was owned briefly by New Zealand Railways in 1900 being numbered No 315. In 1901 the 'D' was sold to the Public Works Department and numbered No 510. Used on the construction of the Stratford - Okakura Line until 1930 when it was scrapped.

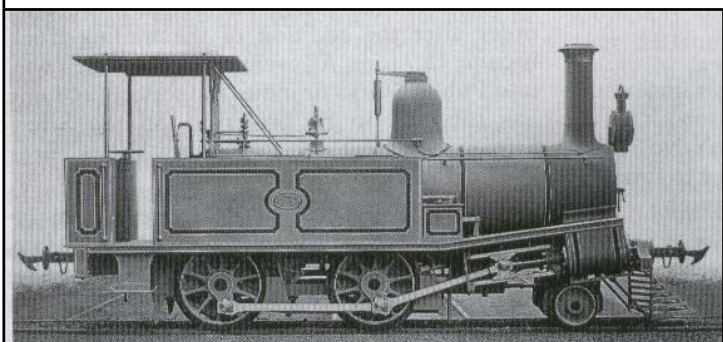

The Generator

These light tanks (17 tons) with their 9 1/2" bore x 18" stroke cylinders, 36 1/2" diameter driving wheels and 160 psi boilers were capable of good work. Fully laden they could manage 25-30mph but when lightly laden they could scamper along at 40-45mph. They had a long working life with New Zealand Railways but by 1927 all had been sold. Their working lives were not yet over as they were quickly bought up by saw millers, freezing works, collieries and cement works.

Surprisingly, considering their long working lives several 'Ds' lasted long enough to be preserved. 'D' No 6 is at the Ocean Beach Railway, 'D' No 16 is at the Pleasant Point Railway, 'D' No 140 is at Ferry-mead, 'D' No 143 is at 'Silverstream', 'D' No 170 Museum of Transport and Technology, and 'D' No 221 owned by the Kaitaia District Council and displayed in Centennial Park, Kaitaia.

An NZR D in G gauge

By Murray Bold

During Locomotion 2003 Grant Alexander, an ex PNMEC member, gave me a "G" gauge power block to use on my garden railway. I took it around to Bruce Geange to see if he had any drawings of locos that I could make use of this power block. The result was a set of drawings for an "NZR D" class loco. One Sunday evening in April 2003 a start was made. The chassis and boiler, side tanks, and cab were soon

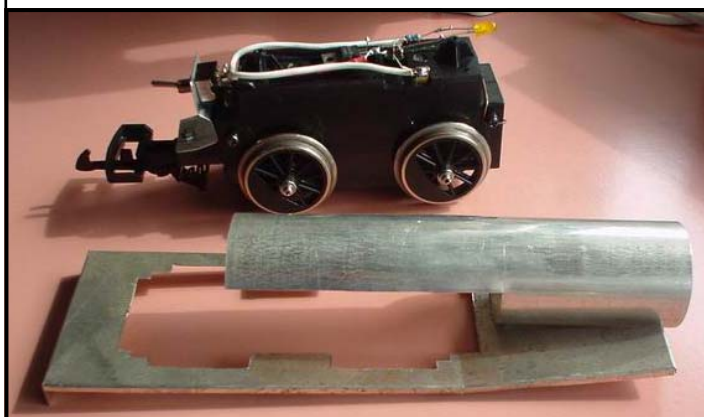

together. By mid May the loco was starting to take

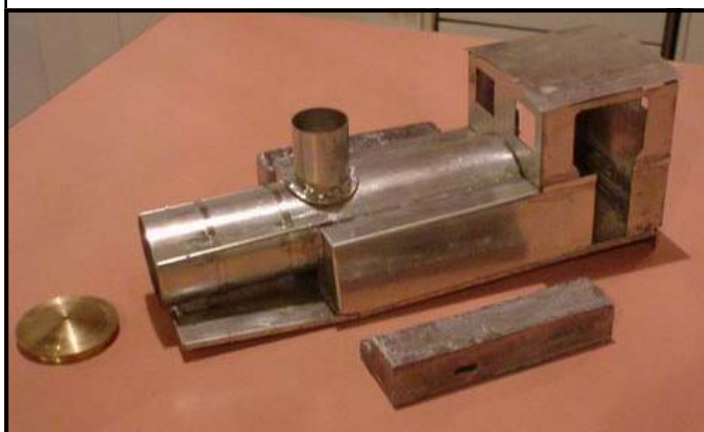

shape. Funnel, steam dome, whistle, headlight, cow catcher and tool boxes were constructed during June and July.



The end of the month saw the model nearing completion but unpainted. During August the painting and lining was completed. The loco was wired up so I can use controlled track power or onboard radio control, with batteries



My D compared to an original



carried in the following freight car. On its first test run the loco had a few problems negotiating the sharp curves of my track but these were soon sorted out and put right. The "D" looks great with the lining and number on the tanks. Thanks Bruce for your help in keeping me focused and therefore helping make this a great looking model.

The following photo shows the "D" with a consist of freight cars. The yellow box car contains the batteries, radio receiver and motor control unit.



More photos of my garden railway can be found at <http://blod.dyndns.org/home/grailway/index.php>

FOR SALE

PETROL- HYDRAULIC 'Hunslet' (7 ¼" gauge)

This is the NZR Dsa built by the late Jim Curtis. Fully detailed the Dsa looks good and runs superbly.

This is a classic example of model engineering. It featured in the Australian Model Engineering magazine (September-October 2002) and comes complete with a purpose built driver's car built to the same standard.



Enquiries to Jean Curtis,
115 Guy Street,
Dannevirke.
Phone (06) 374-7151.
Price \$10,000.

End of Year Dinner.

WHEN: Thursday 24th November 2005
WHERE: Cloverlea Tavern Function Room.
TIME: Gather at 6:30pm. Eat at 7:00pm.
COST: \$21.50 per head.

If you wish to attend please advise
Chris Rogers with names and numbers
Phone (06) 356 - 1759

UNUSUAL INTERNAL COMBUSTION ENGINES

By Doug Chambers

The following will form an ongoing series. Some of the engines were successful and some were not.

I will begin with the Coventry Climax horizontally opposed 16 cylinder. In 1961 the Company was producing a 1½ litre V8 for the Formula 1 Grand Prix. It was believed that this engine would not be able to remain competitive after 1963 although ongoing improvements extended the design life much longer than anticipated.

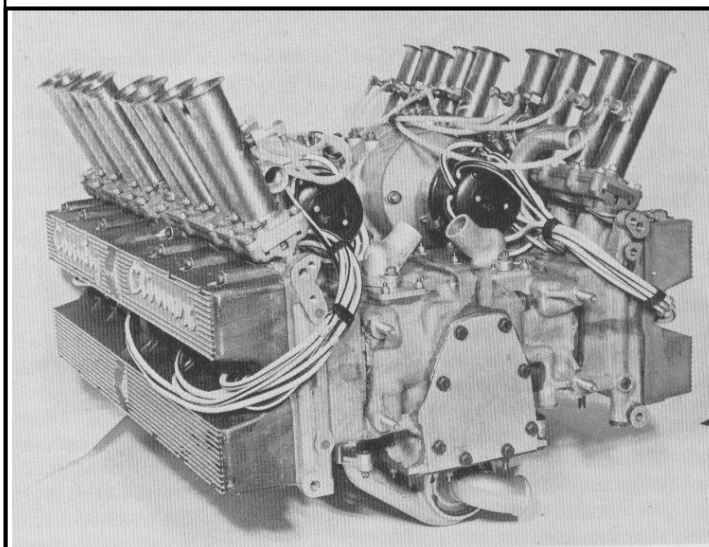

Walter Hassan began designing the flat sixteen-cylinder engine and included some very interesting features. The engines bore was 2.13 inches and the stroke was 1.6 inches. The very short stroke meant that a maximum of 12,000 rpm would be available without exceeding the desirable maximum piston speed.

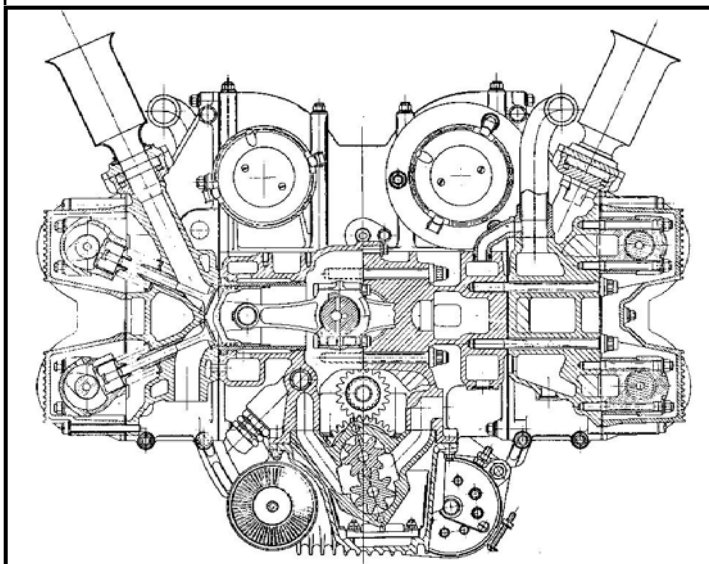

The long crankshaft for a sixteen cylinder is subjected to torsion vibration problems. To reduce the tensional stresses and vibrations the crankshaft was made in two halves. Each half had all the cranks in a single throw but when the crankshaft was assembled each half was at 90 degrees to the other. The coupling consisted of a pinion gear with two tapered stubs. The taper was about 2% and the assembly re-

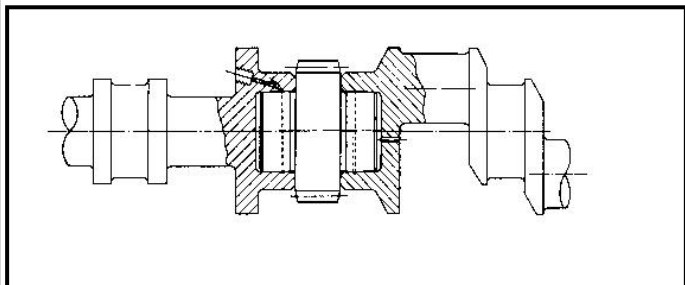

lied on the SKF oil injection process. This was a simple and cheap way of overcoming a difficult design problem.

Assembly of the two crankshaft halves was done by expanding the female tapers using high-pressure oil fed in through an access hole in the crankshaft. While the female taper was expanded the crankshaft was pressed together. Trapped air was able to escape through a small bleed hole.

The crankshaft could be dismantled in a similar way once again using high-pressure oil.

The output power was taken through the centrally mounted gear pinion on the crankshaft and gear ratios reduced the output speed by 25% thus allowing the existing transmission to be retained in the cars. The crankshaft pinion also drove the lubricating and scavenge pumps, camshaft and auxiliary drives for fuel injection pumps and ignition distributors. As there were no 16-cylinder fuel injection pumps or 16 cylinder distributors available, two 8-cylinder pumps and two 8-cylinder distributors had to be used. Even with this the engine proved to be very compact and only weighed 15 pounds more than the V8 unit.

However more problems surfaced when the engine was run on the test bed. Oil drainage to the scavenge pumps was too slow. There was a greater than anticipated amount of horsepower lost driving the valve gear and vibration in the final drive shaft prevented operation of the engine below 3,000 rpm.

In hindsight Walter Hassan believed that four valves per cylinder would have been of great benefit.

In 1966 Formula 1-engine rules changed. The engine capacity was lifted to 3 litres (naturally aspirated) and 1½ litres (supercharged). Coventry Climax were unwilling to start all over again and withdrew from participation in motor racing.